

TR30B+C SPD TUV approved

SPD type 1+2–surge arrester, MOV
Pluggable module, visual fault signalling

- Varistor surge arrester
- Installation to main distribution or sub–distribution boards
- For protection of installations and equipments against impact of induced overvoltage during a lightning strike or switching overvoltages.
- Optional remote fault signalling(s)

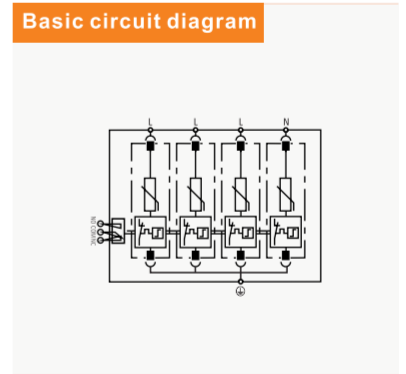
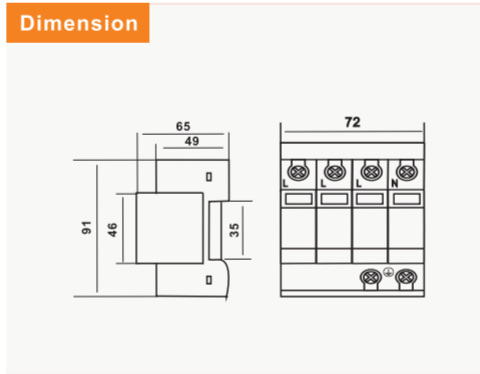

Parameter/Type		TRS30B+C
Nominal voltage	U_n	230V AC
Maximum operating voltage	U_c	275V AC
Lightning impulse current(10/350 μ s)	I_{imp}	7kA
Nominal discharge current (8/20 μ s)	I_n	30kA
Maximum discharge current (8/20 μ s)	I_{max}	60kA
Voltage protection level	U_p	$\leq 1,5kV$
Response time	t_a	< 25ns
Cross–section of connected conductors solid(min/max)		16mm ² /35mm ²
Cross–section of connected conductors stranded(min/max)		16mm ² /35mm ²
Fault indication		red indication field
Remote indication		potential–free change–over contact
remote indication contacts		250V/0,5A AC,250V/0,1A DC
Cross–section of remote indication conductors		1,5mm ²
Degree of protection		IP20
Range of operating temperatures (min/ max)		–40°C~ +70°C
Humidity range		5%~95%
Mounting		DIN rail 35 mm
According to standard		EN 61643–11:2012,IEC 61643–11:2011/T1+T2
Remarks		Other U_c can be customized.(420VAC,385VAC,320VAC,etc.)

T1+T2 AC SPD